



Signaling System



Reference (1/2)

- [1] Wireless and Mobile Network Architectures , Y-Bing Lin and Imrich Chlamtac , Wiley Computer Publishing 。
 - Chapters 2 and 5.
- [2] 第七號共通信號系統概論 ， 湯鴻沼 ， 全華科技圖書股份有限公司 。
- [3] Telephone Network and PBX Software ， Yi-Bing Lin ， 維科出版社 。
- [4] Mobile and Wireless Networks ， Uyles Black ， Prentice Hall 。 Appendix A.



Reference (2/2)

- [5] SS7信號系統，林添財，中華電信訓練所教材。
- [6] Carrier Grade Voice over IP，2nd，Daniel Collins，Mc Graw-Hill Companies Inc.。
- [7] Signaling System #7, 2nd, Travis Russell, McGraw-Hill.



Outlines

- Introduction
- Signaling System Number 7
- Components and Links of SS7
- SS7 Protocol Stack
- SS7 Messages
- PCS/PSTN Call Control Using ISUP
- Summary



Introduction

- PSTN
- SS7 Network Architecture
- SS7 Components

PSTN Architecture

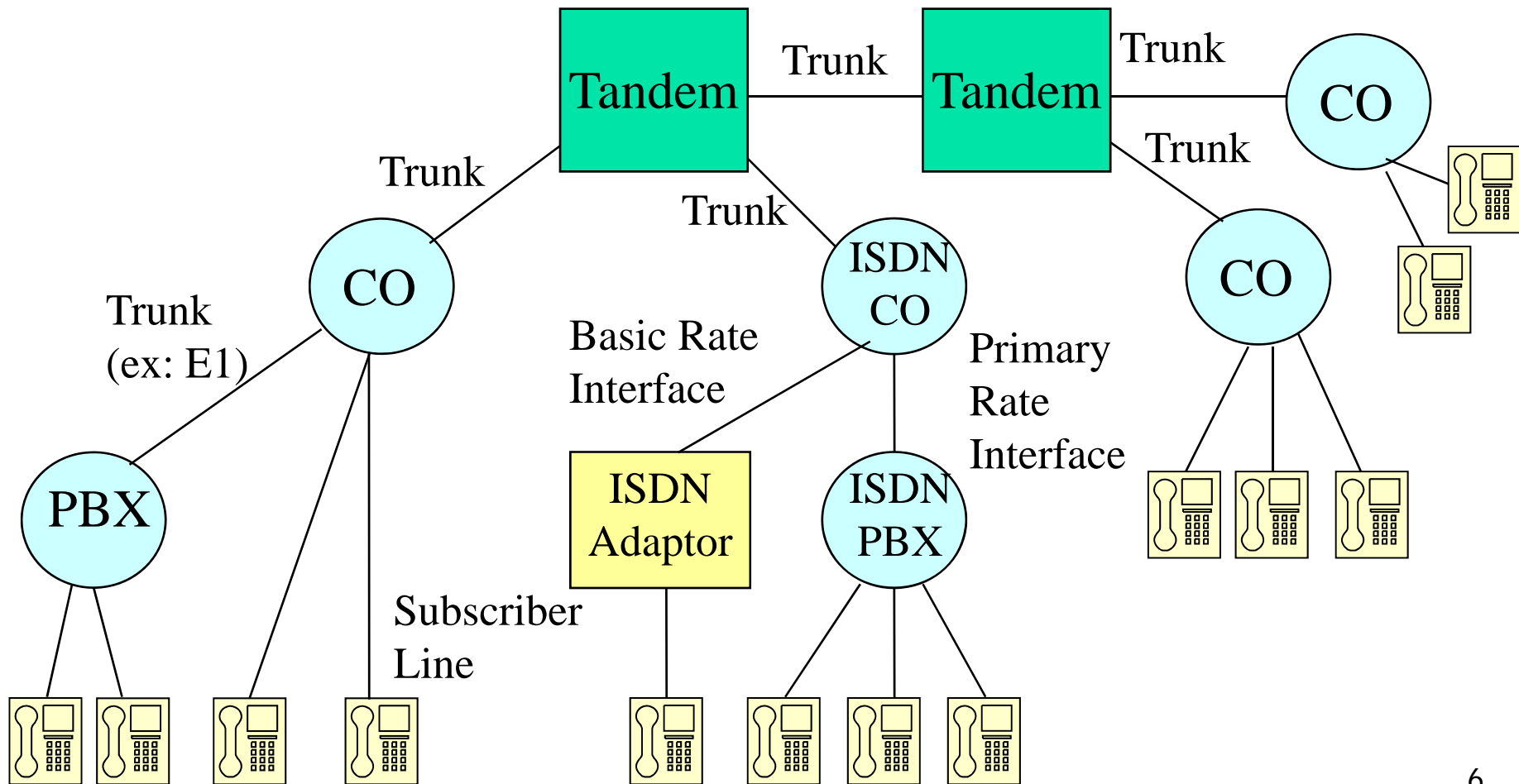



Components in PSTN

- Customer premises equipment (CPE)
 - Telephone set, PBX (Private Branch Exchanges), ISDN (Integrated Services Digital Network) PBX, ISDN Adaptor
- Transmission facilities
 - Trunks and subscriber lines
- Switching system
 - Central offices (CO) or exchange, tandems, ISDN CO

Call Setup and Release

- A call requires a communications circuit between two subscribers.
- The setup and release of connection is triggered by signals.

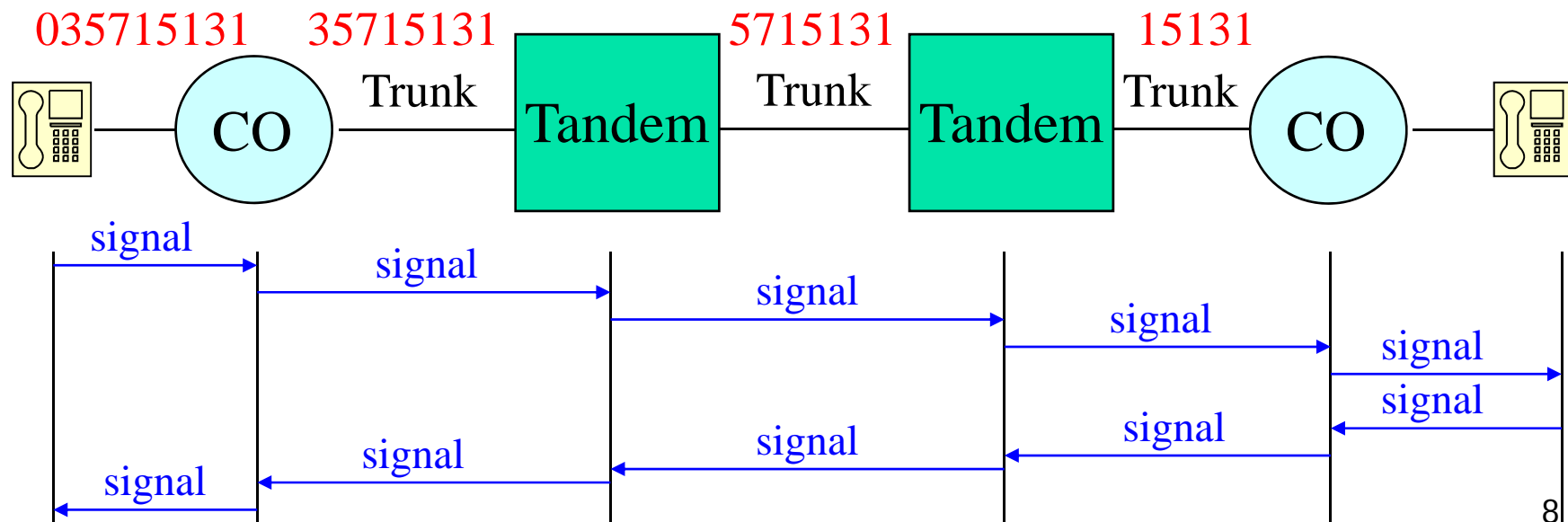



Signaling Systems (1/2)

- Besides delivering subscriber voice and data information, telecommunication network requires a signaling system.
- Signaling is the communication of control information between the signaling elements via some prescribed protocol.
 - For call setup control, administration, disconnect of the circuit



Signaling Systems (2/2)

- Two types of signaling functions:
 - Supervisory signals – initiate a call request, to hold or release an established connection
 - Supervising signals: recognize if subscriber lines/interoffice trunks are busy or idle
 - Call progress signals: provide call status information
 - Alerting signals: provide warning to a subscriber
 - Address signals

Customer-Line Signaling

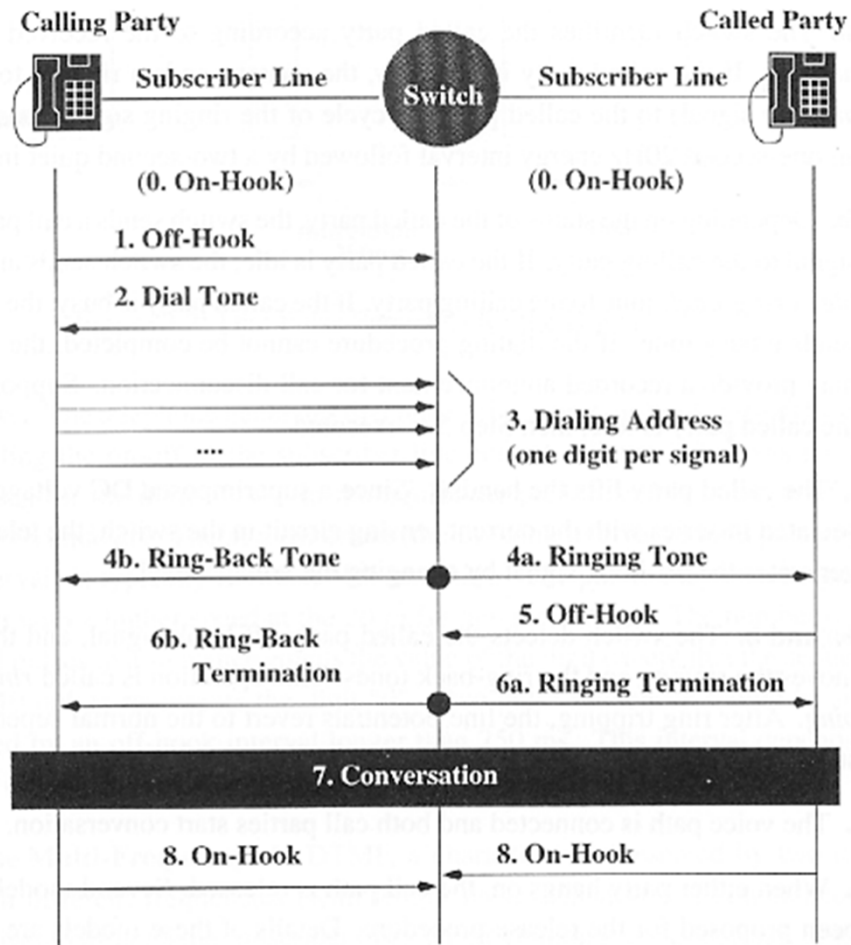

Figure 3.1: Customer-Line Signaling for Call Control

Dial Pulse vs. Dual Tone Multi-Frequency

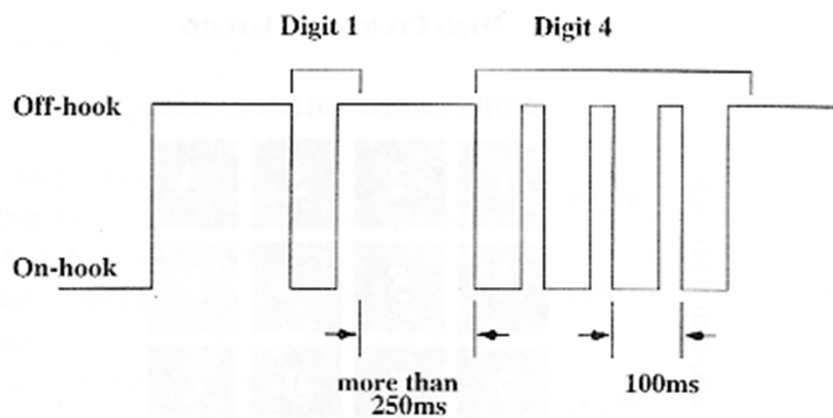

Figure 3.2: Dial Pulse Sequence for the Digits "14"

	1209	1336	1477	1633
697	1	2	3	A
770	4	5	6	B
852	7	8	9	C
941	*	0	#	D



Interoffice Trunk Signaling

- Control information exchange among the switches is achieved by interoffice trunk signaling.
- Two approaches:
 - **Channel associated signaling (CAS)**
 - Signaling and voice share the same *inband* channel.
 - **Common channel signaling (CCS)**
 - A separate *out-of-band* signaling network to carry signaling message.

CAS v.s. CCS

■ Channel Associated Signaling

- Signaling and voice share the same channel

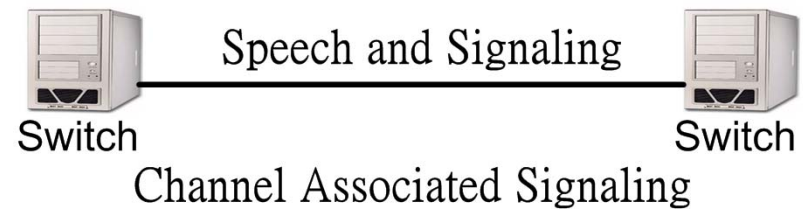

■ Common Channel Signaling

- Separation of signaling and call paths
- Signaling System 7 (SS7)

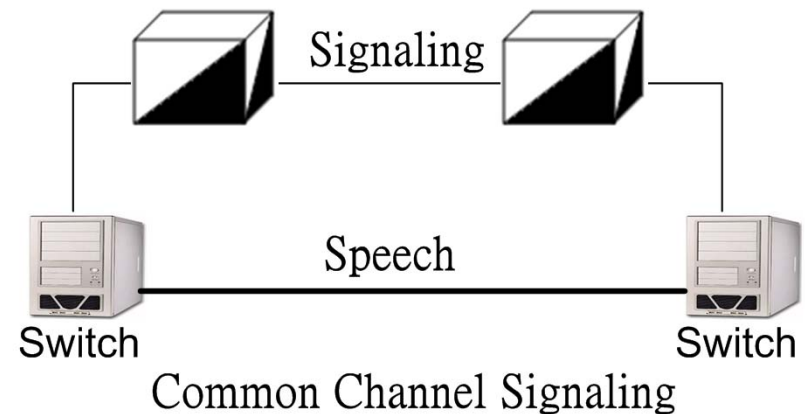



The Advantages of CCS

- Signaling packets can be efficiently delivered using signaling links, which reduces the call setup time.
- Since the ineffective call attempts are released by the signaling links, better utilization of voice trunks can be expected.
- Signaling can be performed during conversation.



Signaling System No. 7 (1/2)

- The first CCS system is **signaling system number 6** developed in the 1970s.
- The modern CCS system is **SS7**.
- SS7 is the foundation for Intelligent Network (IN) services.
- SS7 is a dedicated data communication network and similar to the packet network.
 - **SS7 follows OSI 7 layer architecture.**
 - **Message-based signaling protocol**



Signaling System No. 7 (2/2)

- To enable **a wide range of services** to be provided to the end-user
- Caller ID, toll-free calling, call screening, number portability, etc.
- Signaling between a **PCS** network and the **PSTN** are typically achieved by the SS7 network.

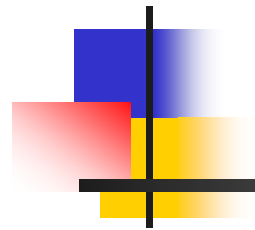

Components and Links of SS7

Signaling Point (SP)

- Each node in an SS7 network is an **signal point (SP)**.
- The signaling address of the SP is known as a signaling **point code**.
- Linkset
 - Group of **signaling links** directly connecting two adjacent SPs
 - For capability and security reasons

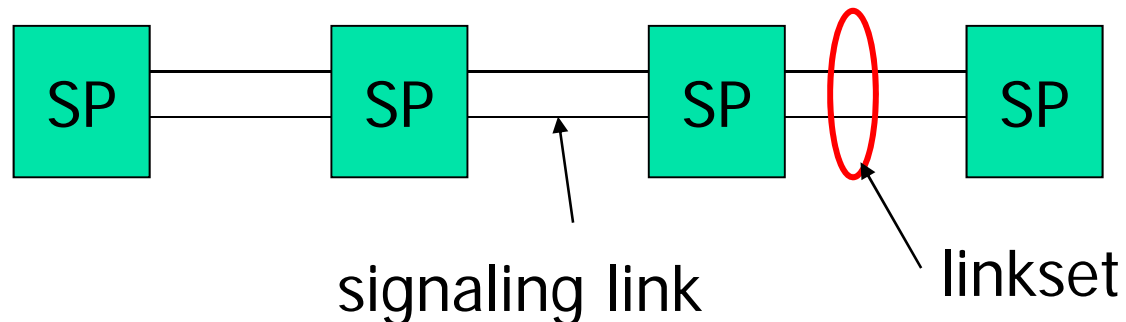

Basic Components

- SSP/Service Switching Point
 - **switching**, service invocation
- STP/Signal Transfer Point
 - signal **routing**
- SCP/Service Control Point
 - service logic **execution**
- IP/Intelligent Peripheral
 - **resources** such as customized voice announcement, voice recognition, DTMF digit collection

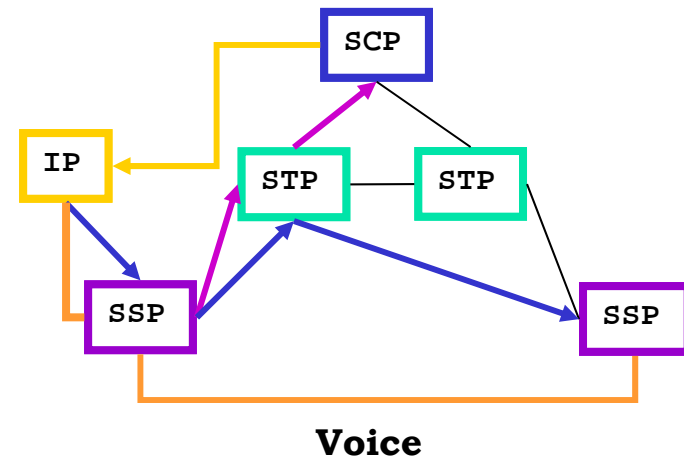

Service Switching Point (SSP)

- Trunks connects SSPs to carry user data/voice information.
- Signaling links connect SCPs to STPs, and STPs to SSPs.

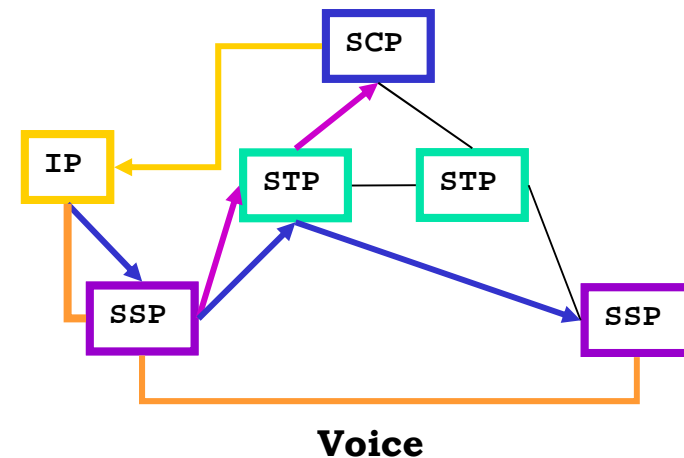

Signal Transfer Point (STP)

- To transfer messages from one SPC to another

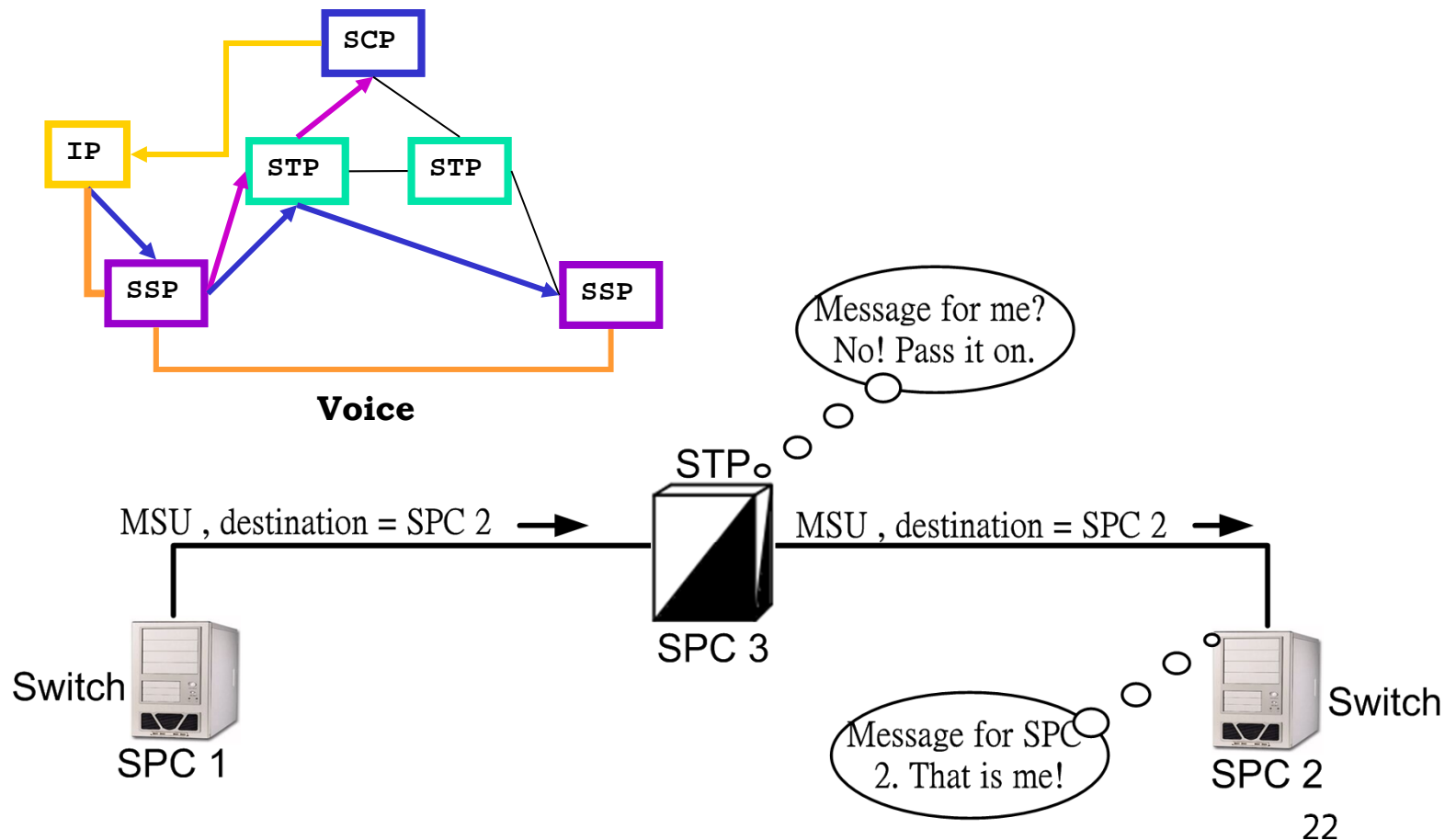



Service Control Point (SCP)

- A network entity that contains additional logic and that can be used to offer advanced services
- The switch sends a message to the SCP asking for instructions.
 - The SCP, based upon data and service logic that is available, will tell the switch which actions need to be taken.
- An good example – toll-free 080 number

Typical SS7 Network Arrangement

- A typical SS7 network arrangement.
- Two switches do not communicate signaling to each other via direct paths.
- The quad arrangement ensures great robustness.

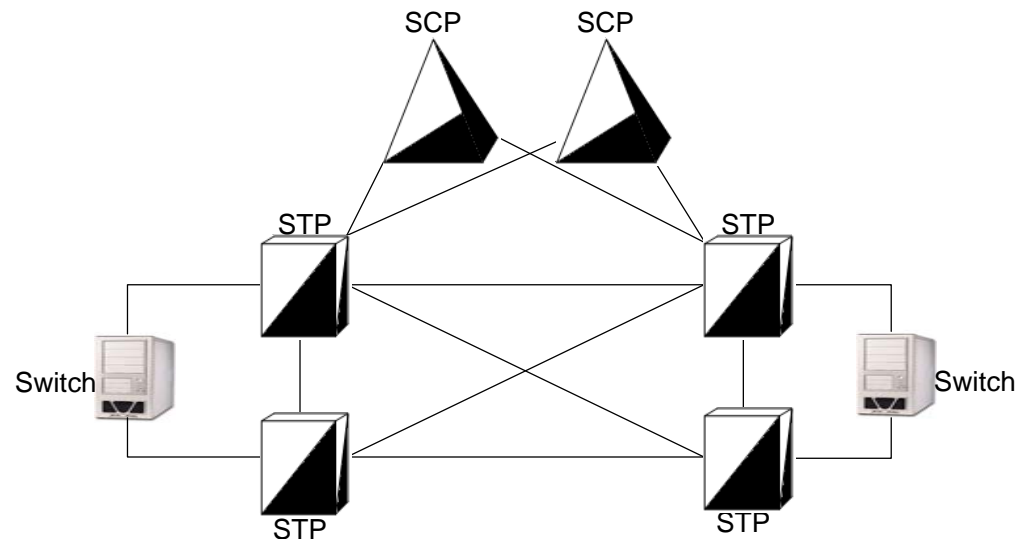

The Telephone Network

SS7 Signaling

----- ISUP Messages

----- INAP/TCAP Messages

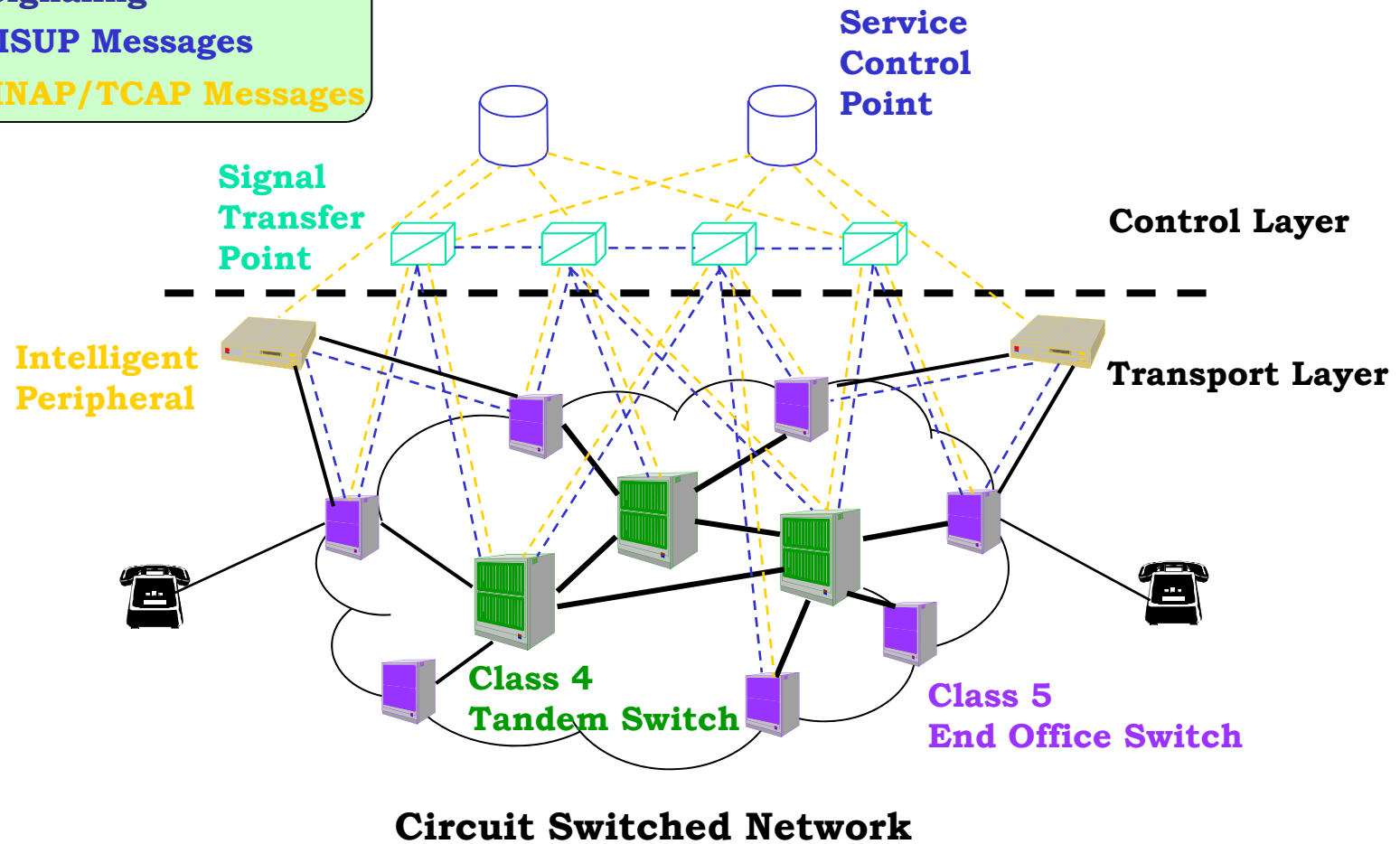

Types of Signaling Links in SS7

Another carrier's SS7 network

One SS7 network

- A-link: Access link
- B-link: Bridge link
- C-link: Cross link
- D-link: Diagonal link
- E-link: Extended link
- F-link: Full associated link

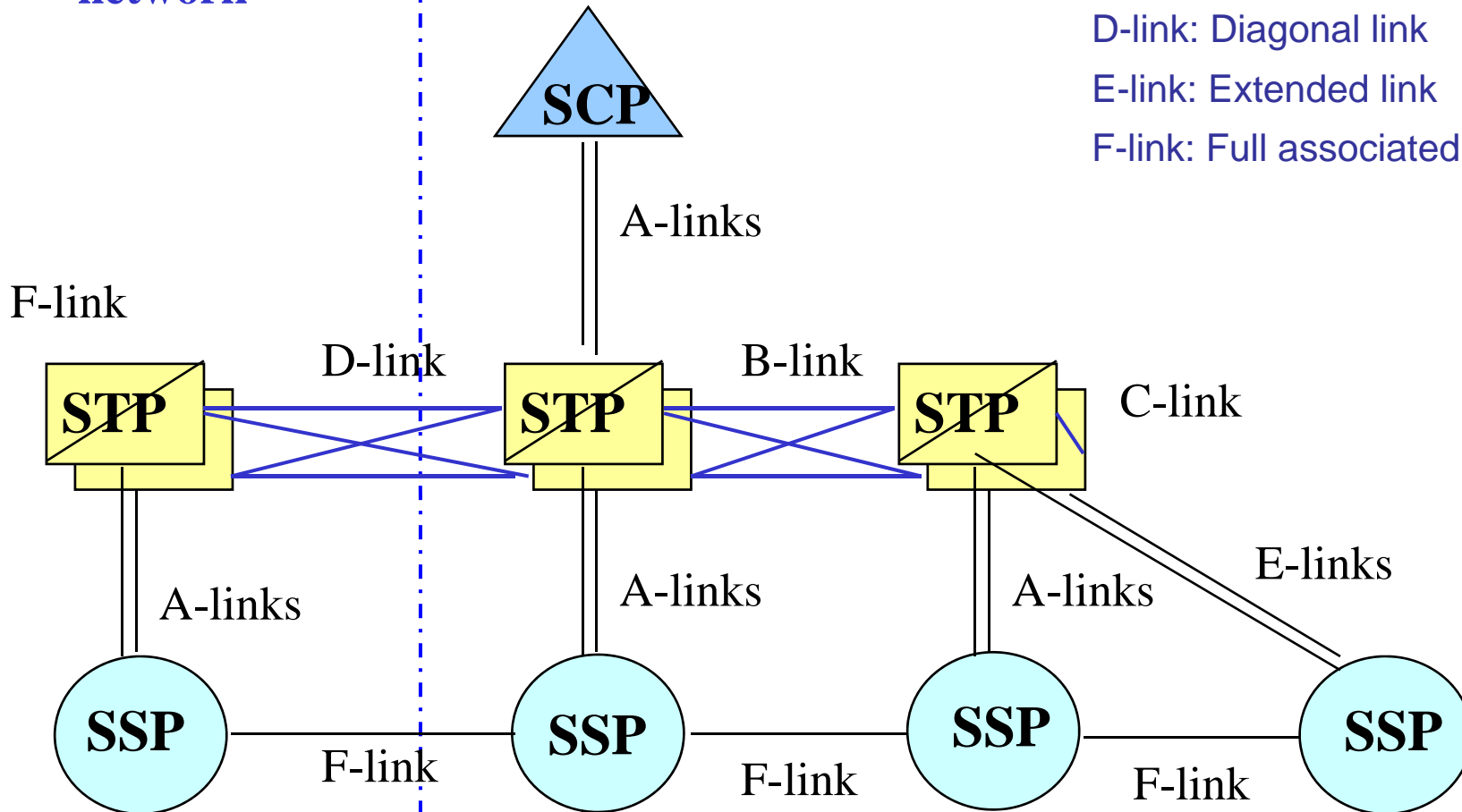



SS7 Protocol Stack

The SS7 Signaling Protocol

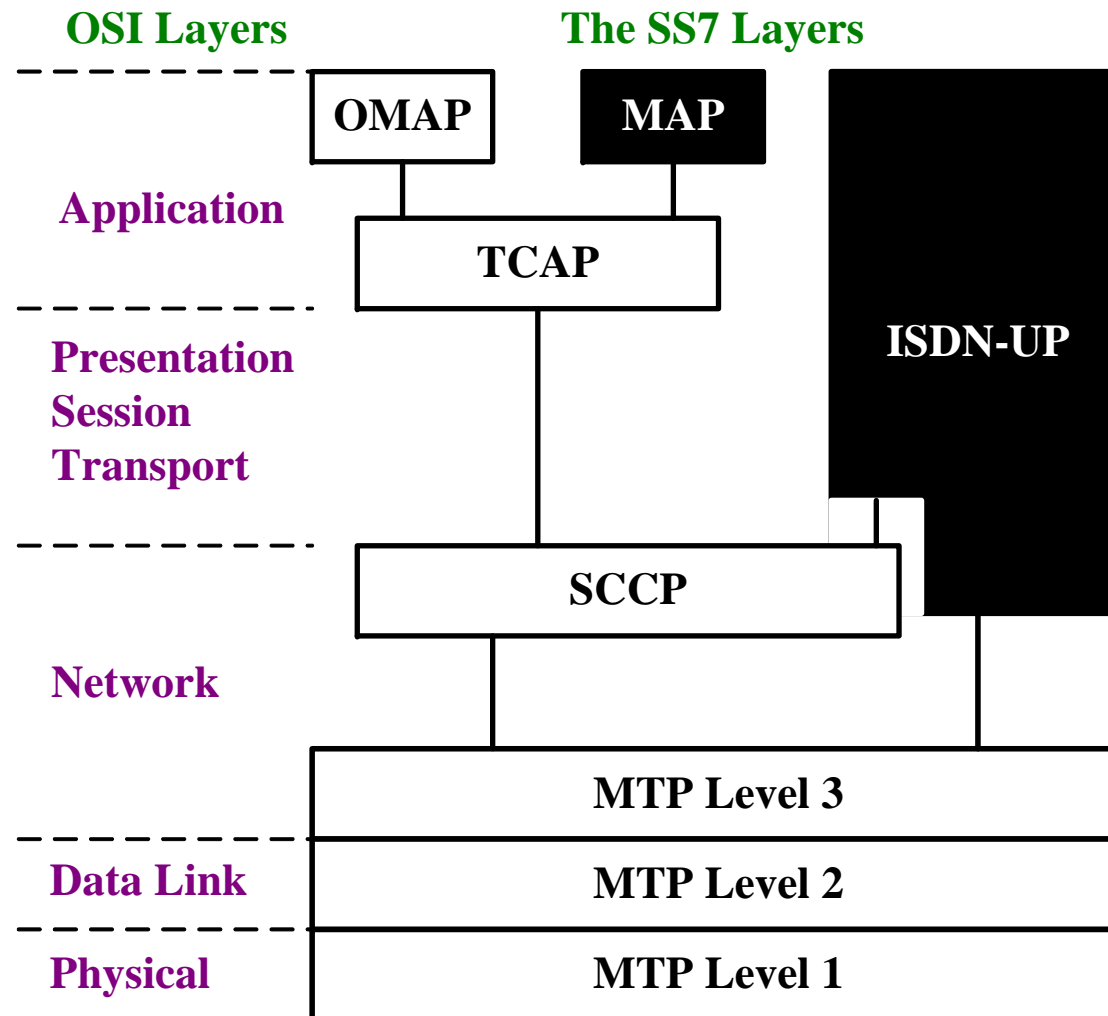

Message Transfer Part (1/2)

- MTP Level 1
 - Defines the physical, electrical and functional characteristics of the signaling.
 - 100111010110000011100111001.....
- MTP Level 2
 - Dealing with the transfer of messages on a given link from one node to another
 - Provides reliable transfer of signaling messages between two directly connected signaling points
 - Error detection and correction, flow control, signal unit delimitation, etc.





Message Transfer Part (2/2)

- MTP Level 3
 - Provides the functions and procedures related to message routing and network management.
- Signaling message handling
 - Providing message routing between signaling points in the SS7 network
- Signaling network management
 - Rerouting traffic to other SS7 signaling links in the case of link failure, congestion or node failure
 - Load-sharing



ISUP

- ISDN User Part
- Used as the protocol for setting up and tearing down phone calls between switches
- Initial Address Message (**IAM**)
 - To initiate a call between two switches
- Answer Message (**ANM**)
 - To indicate that a call has been accepted by the called party
- Release Message (**REL**)
 - To initiate call disconnection



SCCP

- Signaling Connection Control Part
- Used as the transport layer for TCAP-based services
- Both connection-oriented and connectionless
 - Mostly connectionless signaling
- Global title translation (GTT) capabilities
 - The destination signaling point and subsystem number is determined from the *global title*



TCAP

- TCAP (Transaction Capabilities Applications Part)
- Supporting the exchange of **non-circuit related information** between signaling points
- Queries and responses sent between SSPs and SCPs are carried in TCAP messages
- Freephone (800/888), calling card, wireless roaming



MAP and OMAP

- Operations, Maintenance, and Administration Part (OMAP)
- Mobile Application Part (MAP)
 - Application of TCAP
 - IS-41 & GSM MAP are implemented in MAP layer.



SS7 Messages

MTP2 Messages

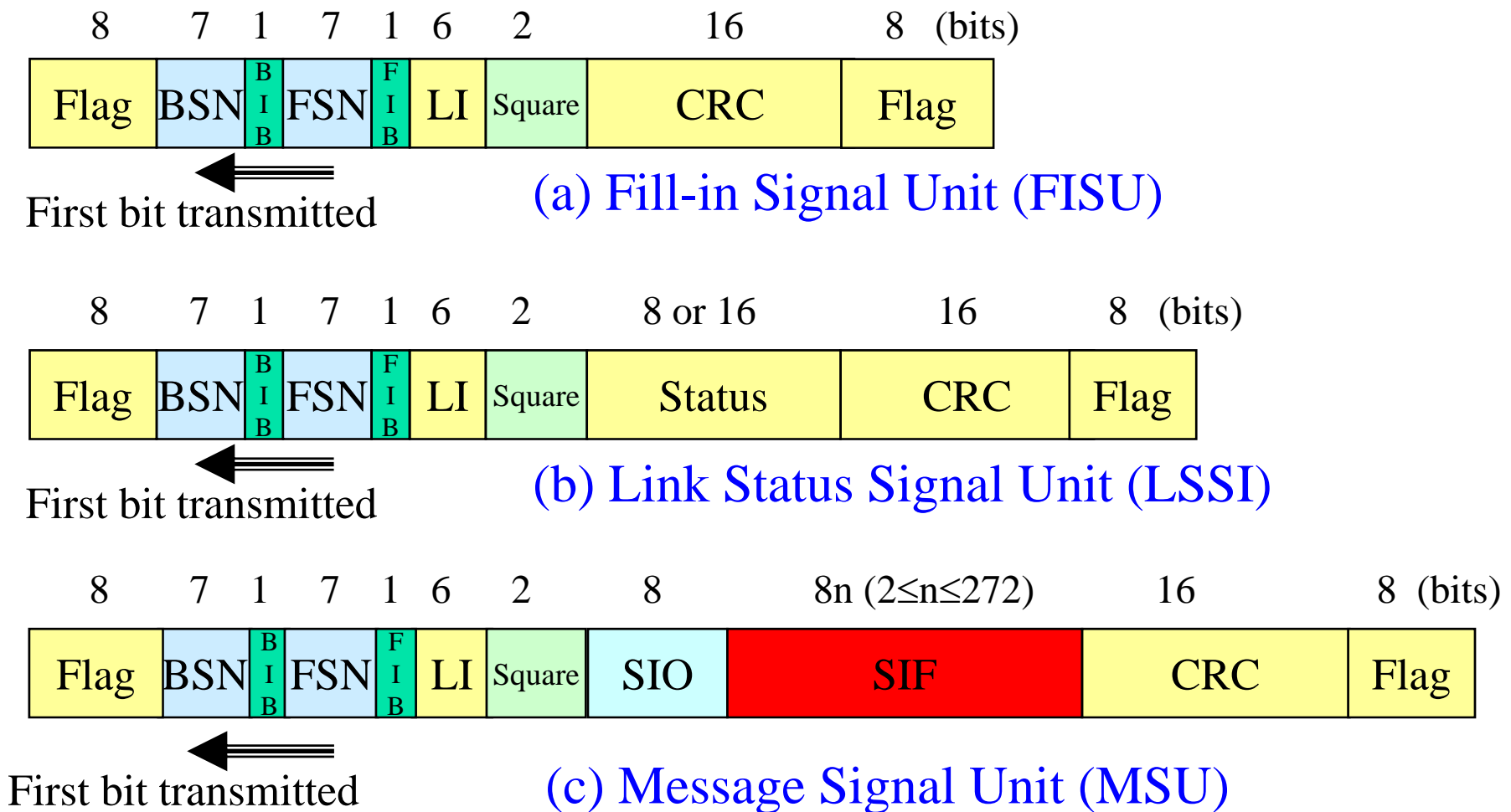

ITU-T Message Signal Unit

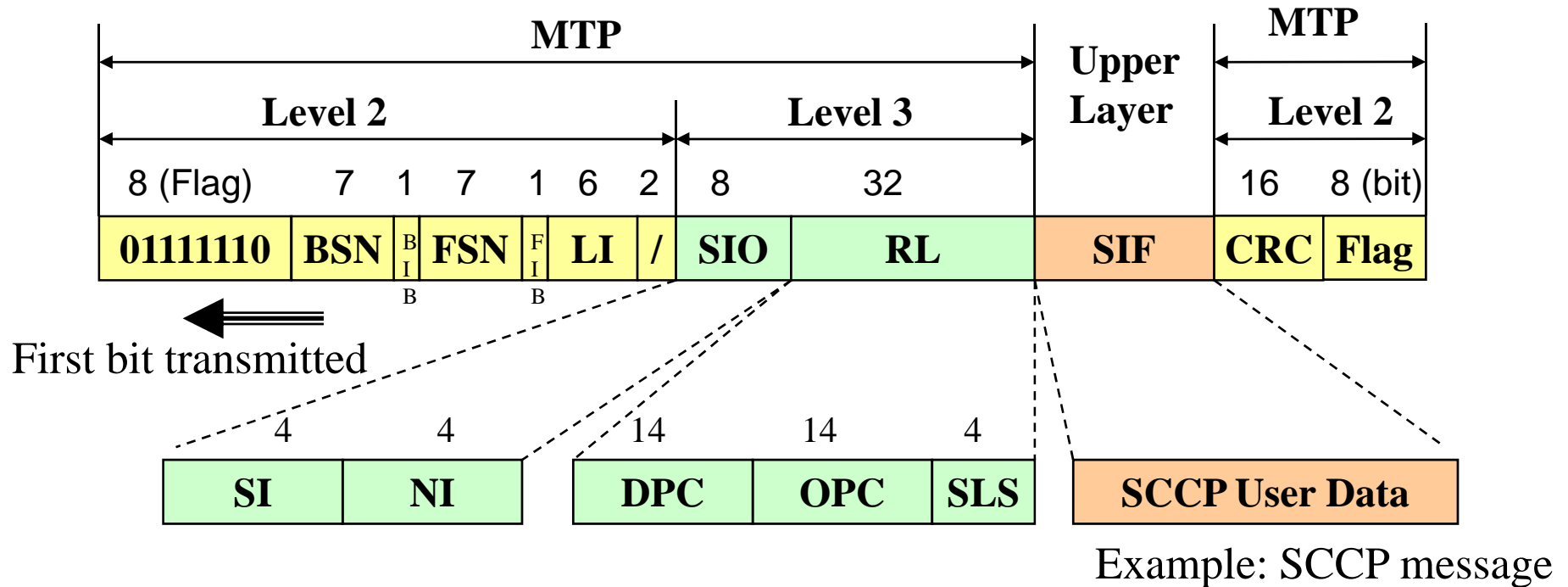

BSN: Backward Sequence Number
 BIB: Backward Indicator Bit
 FSN: Forward Sequence Number
 FIB: Forward Indicator Bit
 LI: Length Indicator
 SIO: Service Indicator Octet

SI: Service Indicator
 NI: Network Indicator
 RL: Routing Label
 DPC: Destination Point Code
 OPC: Originating Point Code
 SLS: Signaling Link Selection
 SIF: Signaling Information Field

Message Signal Unit (MSU)

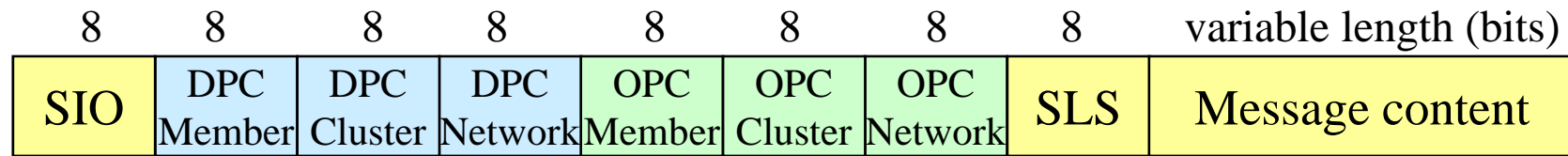

First bit transmitted ←

(a) ANSI MSU

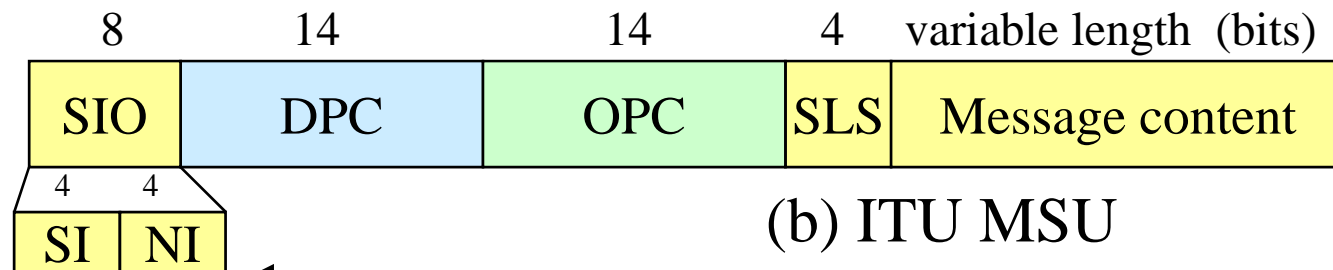

First bit transmitted ←

(b) ITU MSU

- DPC = Destination Point Code
- OPC = Origination Point Code
- SIO = Service Information Octet
- SI = Service Indicator
- NI = Network Indicator
- SLS = Signaling Link Selection

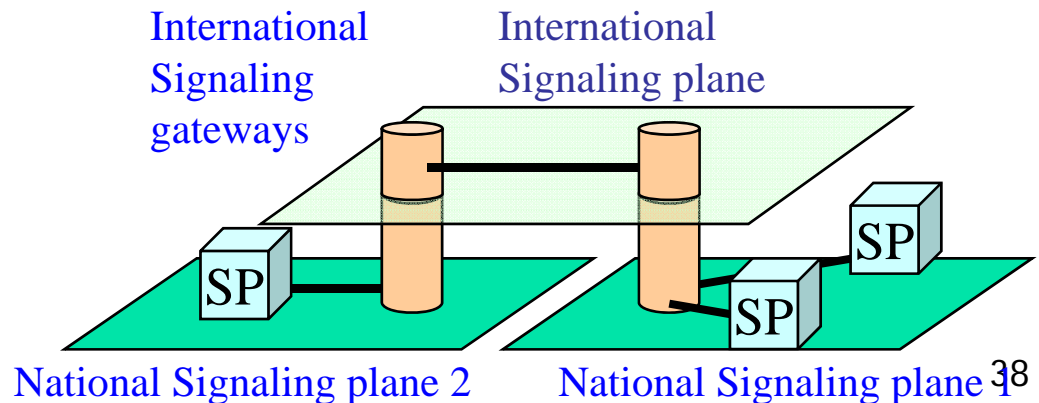

ISUP Message Format

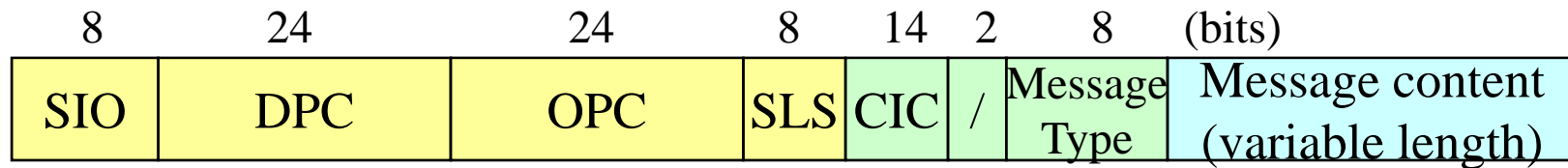

(a) ANSI MSU

←←←
First bit transmitted

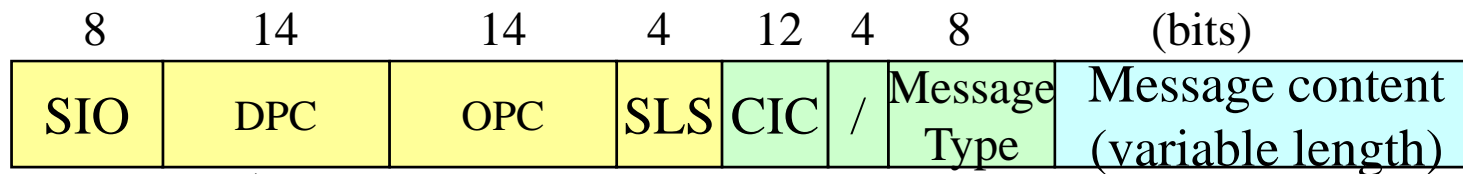

(a) ITU MSU

←←←
First bit transmitted

- DPC = Destination Point Code
- OPC = Origination Point Code
- SIO = Service Information Octet
- SLS = Signaling Link Selection
- CIC = Circuit ID Code



ISUP Message

- ISUP messages
 - Establishes *circuit-switched network* connections
 - Call setup/release between the PSTN and a PCN.
- ISUP messages that are delivered by MTP routing.



ISUP Messages (1/2)

- **IAM** (Initial Address Message)
 - called number, calling number, transmission requirement, type of caller, other information
- **ACM** (Address Complete Message)
 - One-way path from destination to calling switch
 - Note: Called switch generates the ring-back tone.
- **ANM** (Answer Message)



ISUP Messages (2/2)

- **REL** (Release) Message
 - To release the call
- **RLC** (Release Complete) Message
 - Complete the call

Basic Call Setup

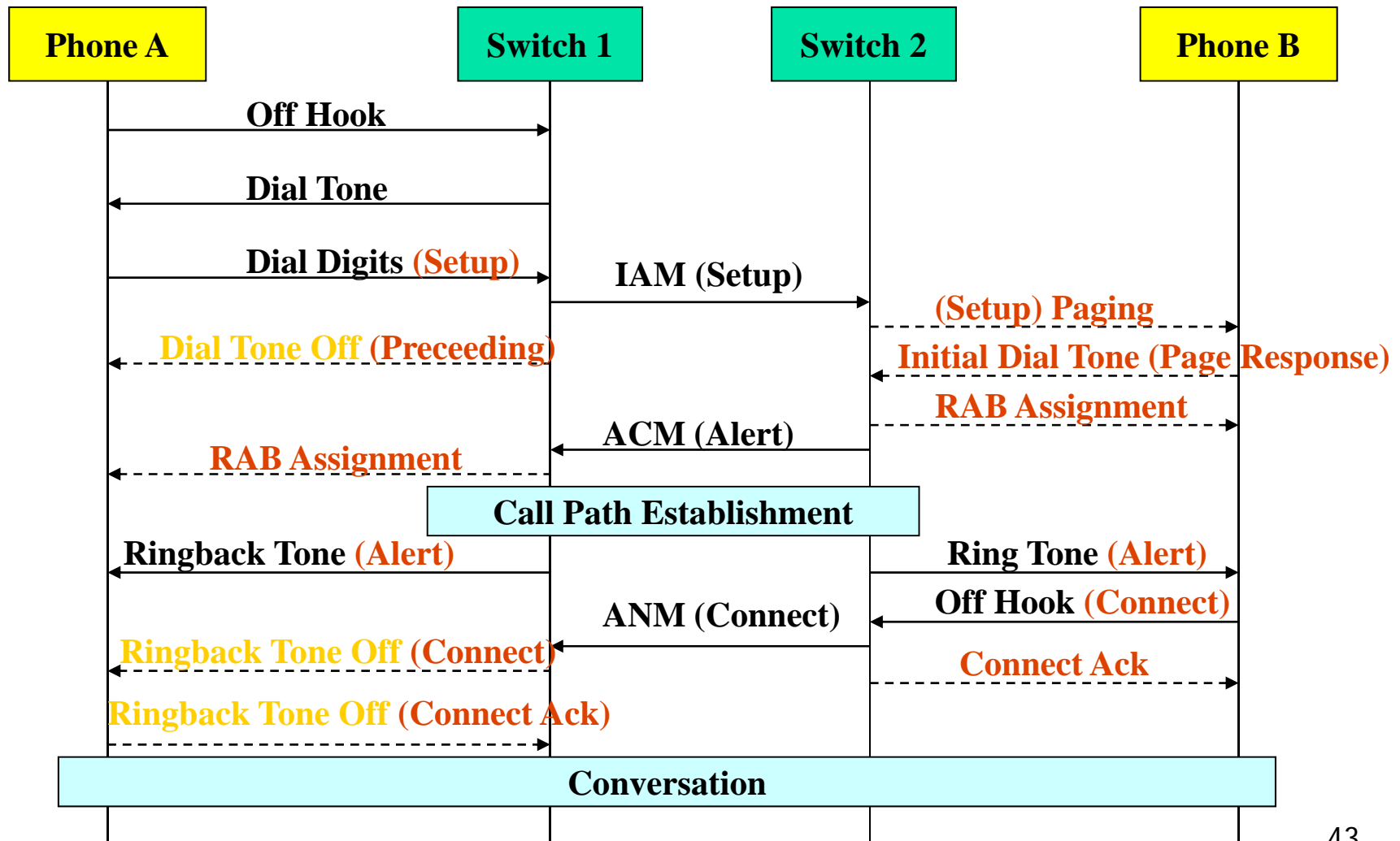

Basic Call Release

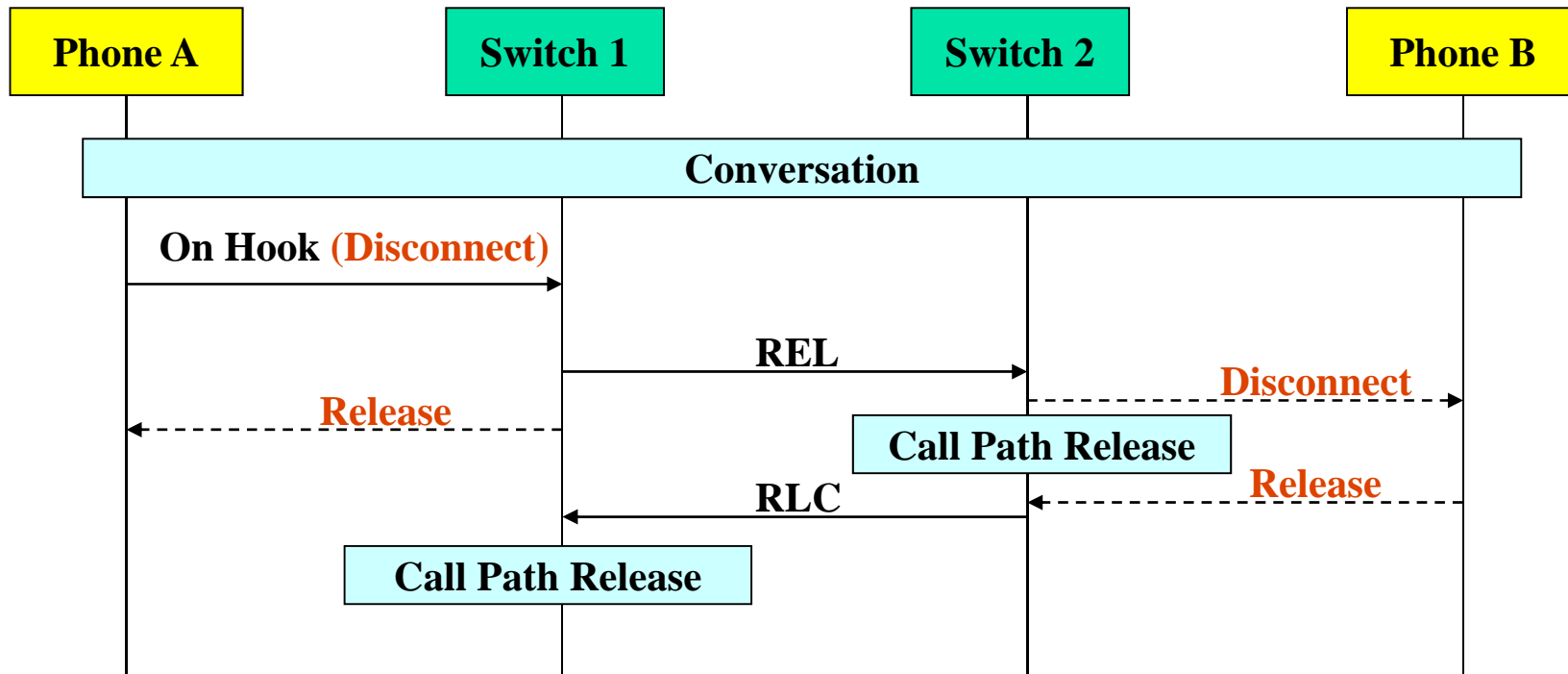

MTP Layer Routing (1/2)

Subscriber Line

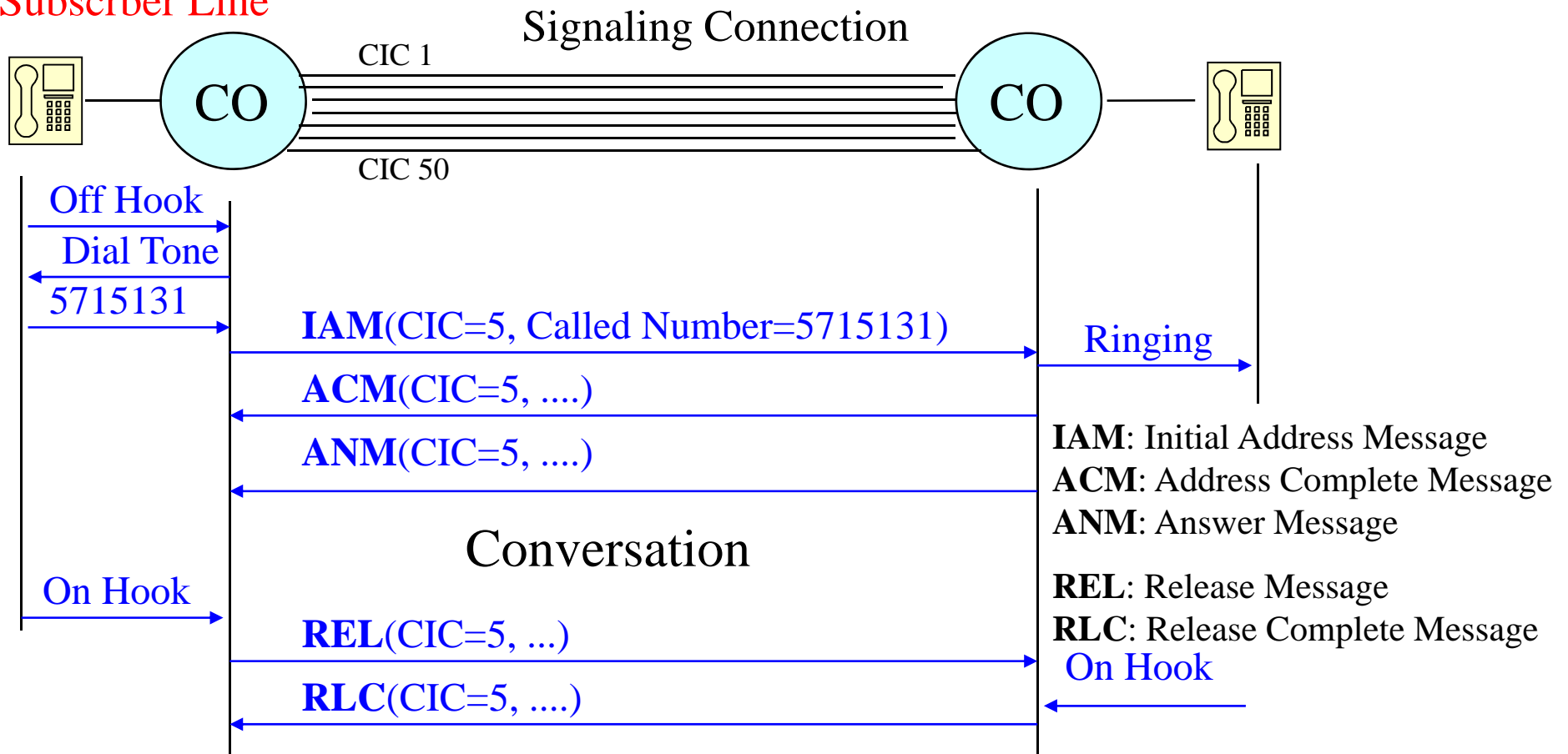

MTP Layer Routing (2/2)

- **Destination Point Code (DPC)** = actual address of the destination node.
- Lookup tables is used in the MTP
- Routing based on DPC

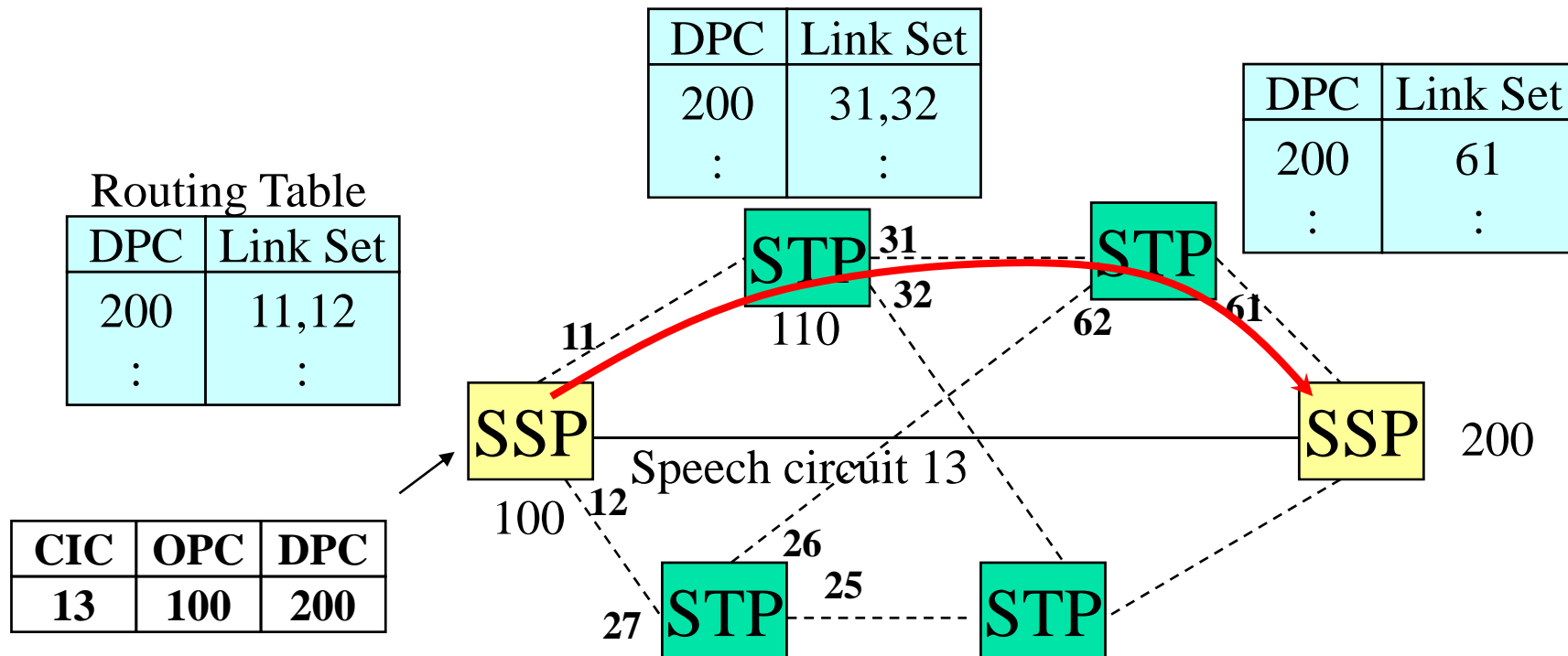



SCCP Layer Routing

- **Global Title Translation (GTT)** is a function defined within SCCP.
 - Performed at a STP or MSC.
- GTT is **the process** of translating a network layer address, dialed digits, or a service subsystem number (SSN), to the **point code** of the destination SSP.
- Routing based on GT translations
 - Called Party Address (**PC+SSN+GT**)
 - Calling Party Address (**PC+SSN+GT**)

ASE	SSN
Reserved	000010
HLR	0000110
VLR	0000111
MSC	0000100
EIR	0000100
AuC	0000101

SCCP Message Embedded TCAP Message

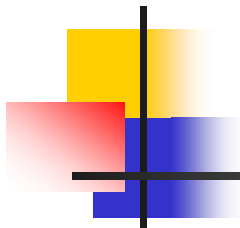

⇒ First bit transmitted

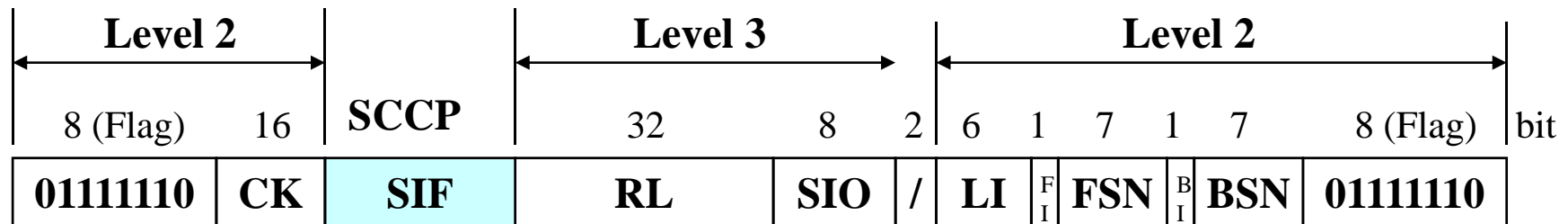

SCCP message

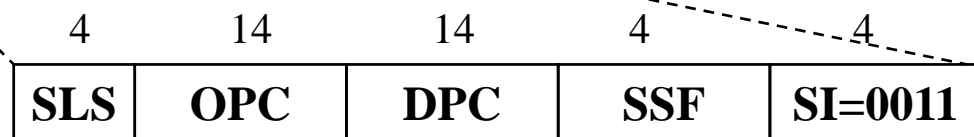

User Data	Calling Party Address	Called Party Address	Protocol Class	Message Type
-----------	-----------------------	----------------------	----------------	--------------

TCAP message

Component Portion	Transaction Portion
-------------------	---------------------

Message Type: Unitdata '00001001'

Protocol Class: Class 0 or Class 1

GTT Example

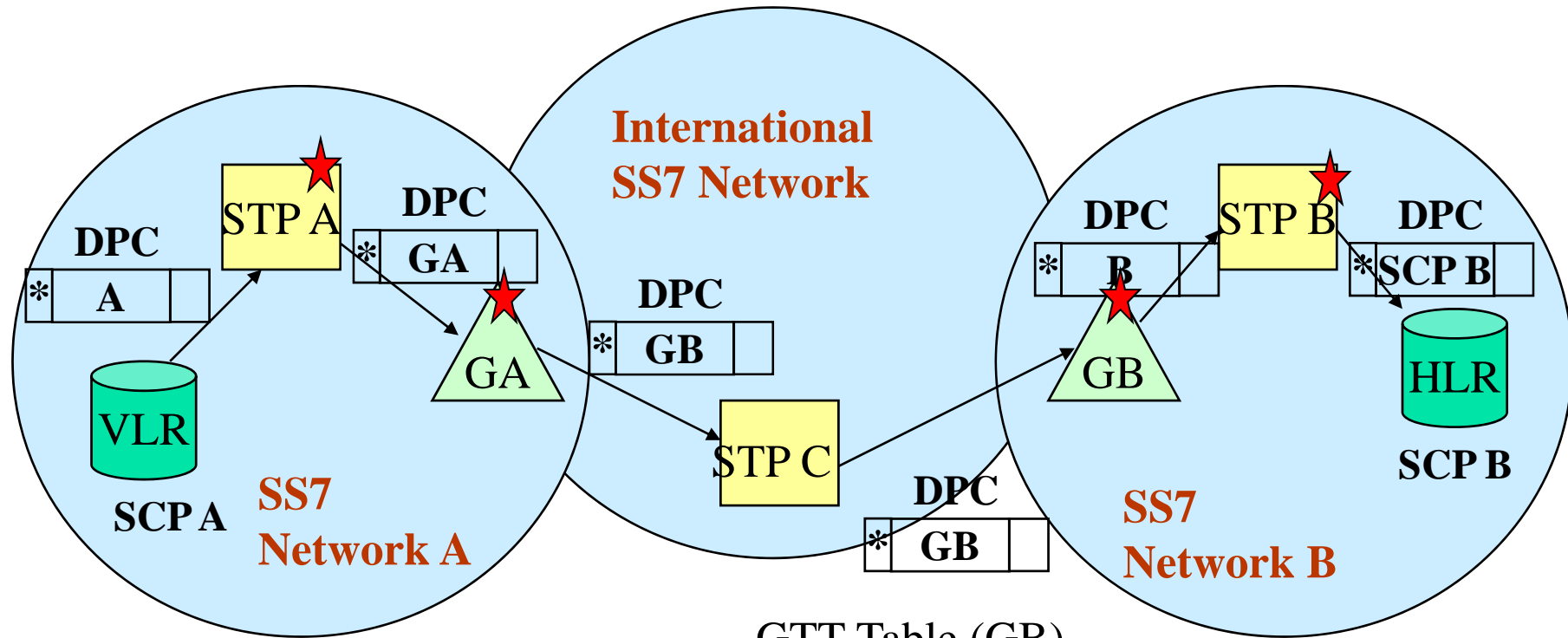

GTT Table (A)

GT	DPC
*	GA
:	:

GTT Table (GA)

GT	DPC
*	GB
:	:

GTT Table (GB)

GT	DPC
*	STP B
:	:

GTT Table (B)

GT	DPC
*	SCP B
:	:

*: Global Title of HLR ★: Perform GTT



PCS/PSTN Call Control Using ISUP

Land-to-Mobile Call Setup and Release

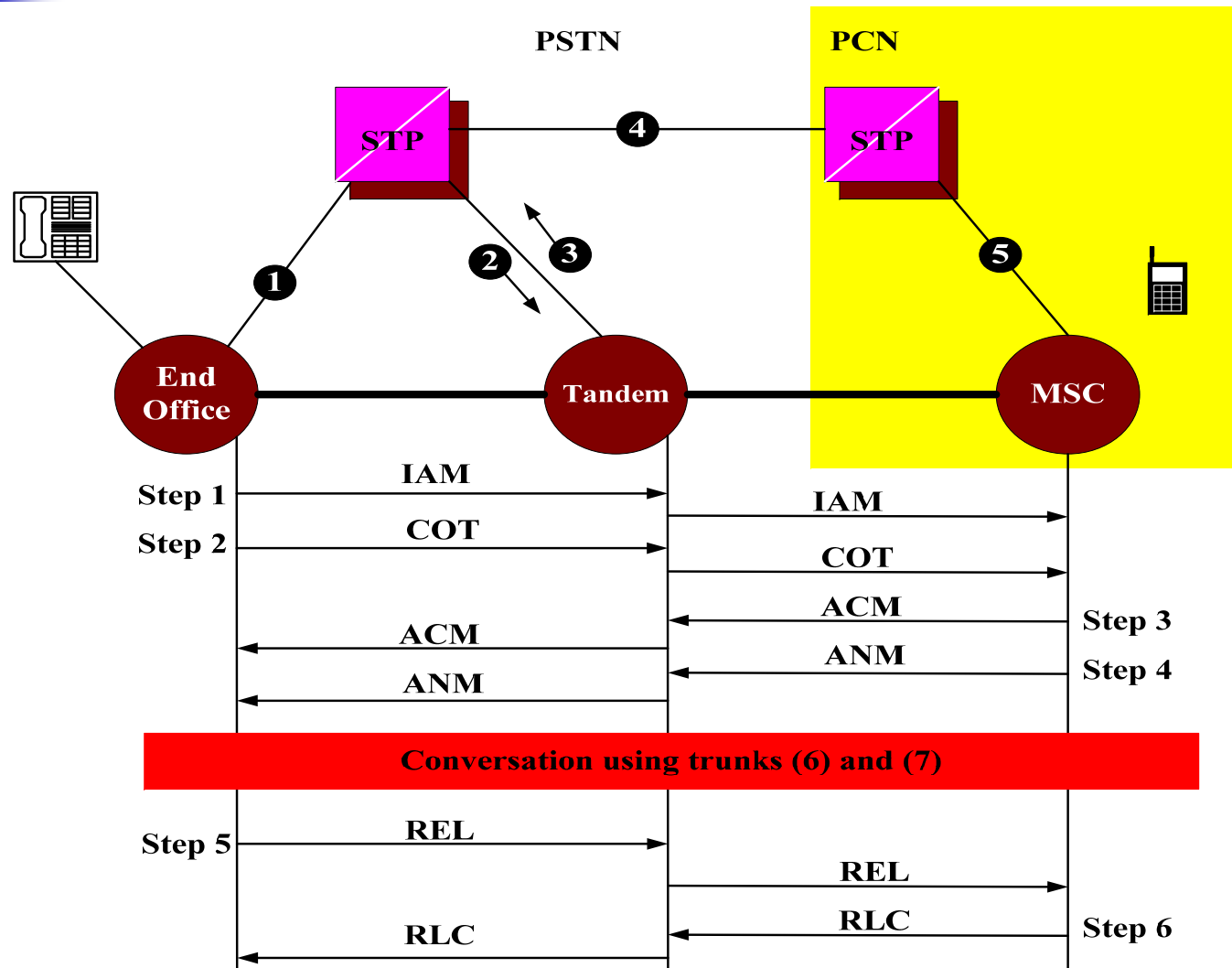

Mobile-To-Land Call Setup and Release

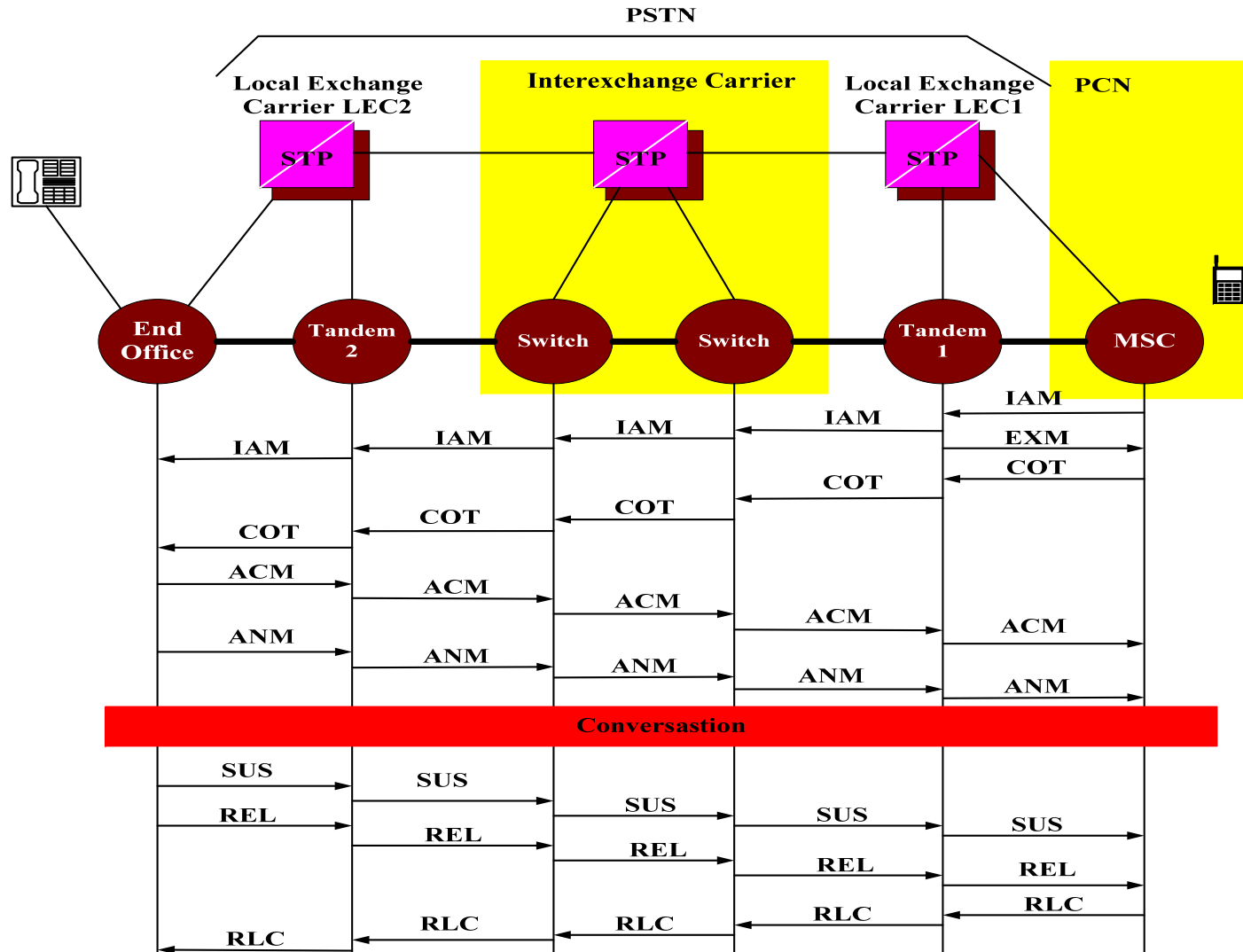



Performance Requirements for SS7

- A given route set should not be out of service for more than 10 minutes per year.
- No more than 1×10^{-7} messages should be lost.
- No more than 1×10^{-10} messages should be delivered out of sequence.
- In ISUP, numerous timing requirements must be met.



Summary

- SS7: out-of-band signaling method
- Components and Links of SS7
 - 3 components: STP, SSP and SCP
 - 6 links: A-F links.
- PCN/PSTN Call Control Using ISUP
 - Land-to-Mobile Call Setup/Release Procedures
 - Mobile-to-Land Call Setup/Release Procedures